



CENTRAL CROSSINGS

MONTHLY NEWS LETTER OF THE

CENTRAL RAILWAY
MODEL & HISTORICAL ASSOCIATION, INC.

Volume 21, Number 6

June 2012

P. O. Box 128
Central, SC 29630

WEBSITE:
www.crmha.org

MUSEUM &
MEETING SITE
108 Werner Street
Central, SC

OFFICERS

President / CEO:
Dan Maret

Vice Presidents:
Ron Keith (1st)
Joe Fitzpatrick (2nd)

Stationmaster
Ralph Watson

Paymaster
Bob Folsom

Webmaster
Ed Welch

Show Chair:
Jim Reece

Museum Curator:
Jack Green

Editor & Producer:
Robert M. Seel, AIA

Next Meeting:
June 7, 2012
7:15 PM
at the
Central
Railway
Museum



CRMHA MEMBERS RAILFANNING!

There's a lot to see in this month's *Central Crossings*, as our members have been hitting the highways. From Kennesaw to Rahway and points in between we've seen stuffed and living artifacts from every generation. **Above, Rob Seel** snagged a DC-bound Acela before it blew him over in Rahway, NJ on May 7, 2012. **Below, Bruce Gathman** shot this Union Pacific trio stomping through south of Mettler on April 28, 2012. 





Upcoming Events for the
Central Railway Model & Historical Association
 as well as Regional shows and events worth mentioning

PROGRAM SCHEDULE

June 7, 2012	Railroad Patents by South Carolinians Bruce Gathman
July 5, 2012	Scotland Steam! Don Baldwin
August 2, 2012	Green on the High Line Rob Seel
September, 2012	Local Railroads, Part 2 Mac McMillin
October 5, 2012	Open Slot Wonder Who?
November 5, 2012	CRM&HA Family Member Patents Bruce Gathman
December, 2012	Christmas Dinner, TBA

2ND SATURDAY

MUSEUM OPEN TO THE PUBLIC

COME RUN TRAINS & HAVE SOME FUN!

JUNE 9, 2012

JULY 14, 2012

SCHEDULED EVENTS & SHOWS

June 1-3, 2012
Gatlinburg, TN
NMRA Southeastern Region Conference
www.ser-nmra.org

June 9, 2012
Greenville, SC
Santa Fe F7 Unveiling!
 10:00 AM – 2:00 PM
Reservation Required.
 Donations accepted for Galveston Railroad Museum
 Motive Power & Equipment Solutions
www.railequipsolutions.com

June 23, 2012
Charlotte, NC
9th Annual NC Rail Fair
 Metrolina Expo Center
 \$6.00 Ages under 12 free. www.gserr.com

August 11, 2012
Norcross, GA 43rd Train Show
 North Atlanta Trade Center www.gserr.com

2012 RAMBLE ONE



JUNE 15-17 2012
 Trip to Chattanooga and Knoxville*
 (Knoxville if Lindie 203 is running)
DETAILS AT THE MAY MEETING
NOTE THE DATE CHANGE
 Call Dale to reserve your spot!
 864-646-2585



GENERAL MEETING MINUTES

By Ralph Watson,
Stationmaster

SERVES THE UPSTATE

May 3, 2012

Regular Meeting at the Central Railway Museum

The meeting was called to order at 7:10 PM by President Marett. 25 members were in attendance.

New members, Deborah Thompson of Easley and James Davidson of Aiken, have also been added.

The Treasurer reported a current bank balance of \$11,000 plus. \$270 was taken in during the Central RR Festival in contributions and Company Store sales which more than paid for the purchase of 4 folding tables to support the Thomas layout.

PRESIDENT'S REMARKS:

Dan thanked the membership for all the efforts made for the Central Railroad Festival which was quite successful. He noted that the Lionel Heritage Room is ready for wall and ceiling finishing and asked for volunteers.

The backdrop patch behind the projection screen needs to be mudded and painted.

The American Flyer Heritage Room needs some step benches for small kids to get a better view.

OLD BUSINESS: No discussion

COMMITTEE REPORTS:

Train Show: No report.

Museum Building: Power supply is wired for the flashing crossbuck lights with some minor details for completion.

Central Railroad Festival: Was well attended and CRM&HA had many visitors both at the main museum and at Function Junction.

Portable Layout: Track plans and benchwork are under review for enlarging the layout. The trailer will be closely measured for capacity limits.

Lionel Room: No report.

American Flyer: No report.

Programs: Programs are booked into 2013.

Webmaster: No report

Newsletter: Rob thanked all for the contributions and solicited layout tour photo sessions of members' layouts.

Museum Curator: No report.

Railfan News: Mac McMillan reported that NS is replacing track-side signals in the area. It is unknown whether the removed equipment will be available as artifacts.

Property Inventory Administrator: Work continues on the database.

Publicity: No report.

Computer Administrator: Internet access has been obtained for the desk computer. Ron Keith has donated another computer.

HO Layout:

Benchwork: No report.

Track Work: Bob Folsom and his track gang are working to repair/replace faulty sections and to connect the paper mill to the main line. Work will be done in stages to keep the main line open whenever feasible.

Rolling Stock: At least 100% more freight cars are needed to operate the HO layout. Locomotive and DCC decoder budget is exhausted.

Scenery: The logging camp area of the upper deck has been given a whole new painting by Jim Kimble and Jim Reece with great success.

Operations: No report.

NEW BUSINESS:

Dan would like to schedule an Open House for families and friends on July 13 to show them what it is we do while away from home.

Notice was received after Newsletter deadline of an estate sale in Helen, GA on May 19 including a large amount of HO model railroad related items.

PROGRAM:

Don Baldwin showed many slides taken during his many trips to Austria and had models of Austrian railroad equipment and track-side environs. 

M.O.W. CRAWLER
IT'S NOT ALL HIGH-TECH
PHOTOS BY HOWARD GARNER



February 25, 2012 - Buford, GA. Collecting bundles of old ties is easy work when you have a track hoe with a claw and a string of gondolas. It's also easy to move from one gon to another, as Howard witnessed and displays for us. The short MOW train was pulled by a single SD40-2. 

PATENTLY SPEAKING

Submitted by Bruce Gathman

There are generally two parts to patent submissions: a written description of the invention and drawings (not to scale) that are keyed to this written description. Depending on the complexity of the invention more than one page of descriptions and/or drawings may be required to fully explain the merits of the design. You may find these descriptions online at—
<http://patft.uspto.gov/netahtml/PTO/patimg.htm> by entering the patent number in the “view patent” box.

**LOUIS CARUSO, OF IRVINGTON/NEW JERSEY, ASSIGNOR TO THE LIONEL CORPORATION,
 OF NEW YORK, N. Y., A CORPORATION OF NEW YORK**

BUMPER

Application filed January 19, 1929. Serial No. 333,562.

The present invention relates to bumpers and is more particularly directed toward the provision of a bumper adapted for use on toy railway outfits.

The present invention contemplates the provision of a bumper suitable for toy railways so arranged that the act of placing the bumper on an energized section of toy railroad track will automatically illuminate the bumper.

A further object of the present invention is to provide a bumper which can be readily secured to toy railroad track so as to prevent trains on the track running beyond the desired stop.

The accompanying drawings show, for purposes of illustrating the present invention, one of the many possible embodiments in which it may take form, it being understood that the drawings are illustrative of the invention rather than limiting the same. In these drawings: Figure 1 is a longitudinal sectional view through one form of bumper; Figure 2 is an end view of the bumper taken in the direction of the arrow 2 of Figure 1; Figure 3 is an enlarged sectional view through the lower part of the lamp socket; and Figure 4 is a diagrammatic view illustrating the wiring.

April 1, 1930.

L. CARUSO

1,752,731

BUMPER

Filed Jan. 19, 1929

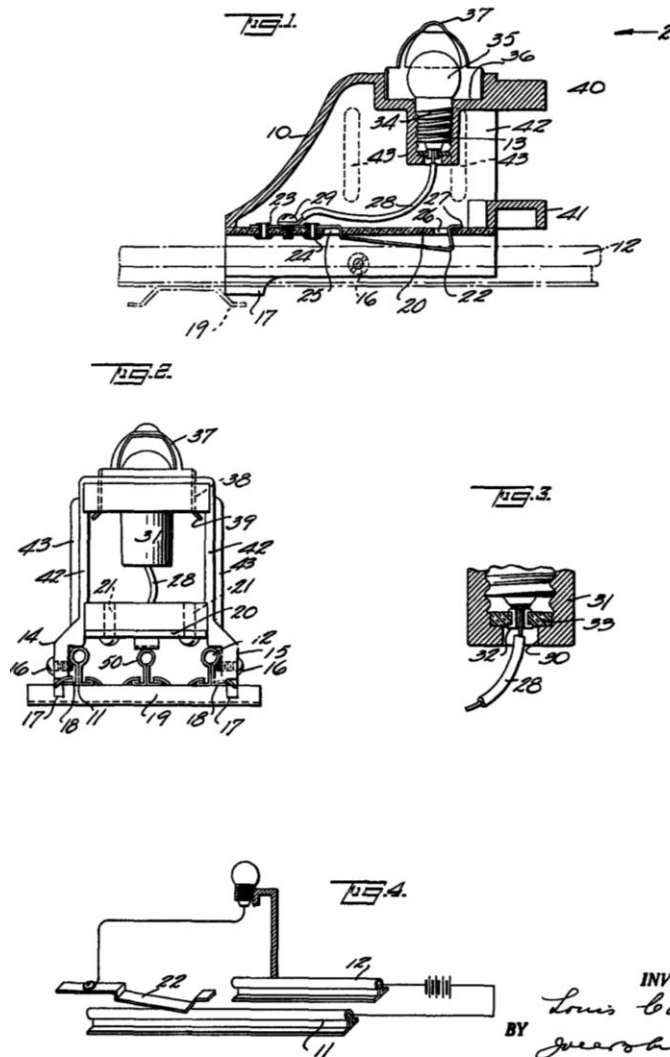

INVENTOR
Louis Caruso
 BY *Geo. A. Liberman*
 ATTORNEY

CSX BRASS VISIT KENNESAW

🌀 BIG SHANTY MUSEUM 🌀

APRIL 11, 2012



By Bill Moorhead. Cheryl and I attended the Great Locomotive Chase commemoration event with Lionel Collectors Club of America at the Southern Museum of Civil War and Locomotive History in Kennesaw which is right at the Big Shanty site. The museum is awesome and they had a great Open House event. CSX had an executive train on site and open with special tours for LCCA. I have attached our few photos -- get a look at that observation car! All are beautifully restored and modernized. These units had been at the Masters and were to become part of the larger consist for the Kentucky Derby, at which CSX was to have dining car facilities to seat 350. The museum was thrilled to have CSX participating in this way on the siding adjacent to the restored station on the grounds.

We were especially interested in this event because my great grandfather, Frank Hawkins, was one of the raiders in the first attempt that failed for lack of an engineer. The raiders that did steal the train were most from my hometown and county in Ohio. William Pittenger, a raider and author of *Daring and Suffering*, the account of the raid and chase, was a soldier from Steubenville, Ohio and served as the war correspondent for the *Steubenville Herald Star*, our hometown paper.

While enjoying the museum following an extensive behind-the-scenes tour with LCCA (including meeting some of the CSX executives and chef), we happened onto another attendee who was the engineer on the *General* when it went to DC in 1972 following the US Supreme Court decision that confirmed the *General's* permanent custody in Georgia over the lengthy legal objections of Tennessee. He had some fun insights to share from his railroading days as well as the modern day-pre museum-days of the *General*. 🚂

EASLEY TO SEE WHAT'S OLD AND NEW AGAIN

ON THE CLCX/PICKENS SIDING



Above: NS CW40-9W No. 9843 blasts through Easley on April 27, 2012, past the CLCX-refurbished GP10 for Waste Management. The 8379 was built in 1958 as GP9 No. 9379 for the Illinois Central, where it was rebuilt as a GP10 and renumbered to 8379. The unit also served the Carolina Piedmont before being transferred to Johnson Rail Services. **Top photo by Bruce Gathman.**

Below: Johnson Rail Service's No. 90 (S1?) is next on the line to be transferred to Pickens. **Photo by Howard Garner** on May 22, 2012. According to Howard, the "CatTronic" remote control system is already installed and may be just in town for painting. 🚂



SAGE'S PAGES
BALTIMORE & OHIO MUSEUM
BY SAGE VIEHE



October 9, 2011. This is 1309, a C&O class H-6 2-6-6-2. It was the last steam locomotive built by the Baldwin Locomotive Works (1949). Many articulated locomotives are erroneously called "Mallets." 1309 is a true Mallet: It is both articulated and has high and low-pressure cylinders.

Similar to, but much bigger and heavier than the 2-6-6-2 were the famous 2-6-6-6 Alleghenies, built by Lima for the C&O. Only two Alleghenies survive, one of which – the 1604 – is in Baltimore. ~ ed.

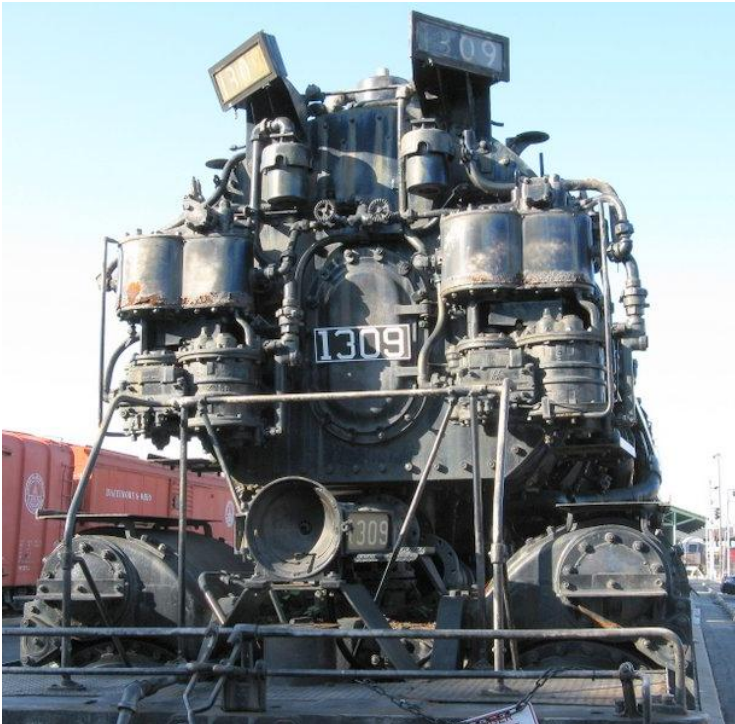

HAPPY ACCIDENT SIDE TRIP HAGERSTOWN ROUNDHOUSE

PHOTOS BY ROB SEEL





By Rob Seel, May 4, 2012 – Sometimes surprises while traveling are pleasant ones. Such was my visit to the Hagerstown, Maryland Roundhouse Museum. Honestly, I was driving through town seeking a gas station when I drove past, did a double-take, and turned around. It's not a big place, but they do have a pretty smart collection of equipment, artifacts, and model layouts. The Western Maryland Railway roundhouse is gone, demolished in 1999. But, one of the end structures remain and it houses the museum. The museum sits on the edge of CSX yard property, so please watch your step where you wander! Among the outdoor displays are ex-Western Maryland No. 132, a Baldwin VO-1000, built in 1944 (**above right**), and a string of cabooses with an ex-B&O ribbed bay window cab (**page 10**). Inside, there are miscellaneous signal heads, tools, machinery, and three model displays upstairs. **Top left**, an HO diorama occupies a corner of the large room where the HO layout (**middle left**) dominates the scene. **Bottom left**, a very large S-scale layout features speeding trains, tight curves, and a huge freight yard. So if your ever in town, I highly recommend a visit. *Stay tuned for more from my trip next month!* 🚂